

Westell® | CS19-BBU-002-48 Series

12/24 Hour NFPA Compliant Battery Back-up Enclosure

General Information

Westell's CS19-BBU-002-48 series of Public Safety Battery Backup Units are designed to provide main power and uninterruptible backup power for any -48VDC public safety bi-directional amplifier (BDA) system. The CS19-BBU-002-48 series can maintain full continuous operation of a BDA for 24 hours or more depending on battery installed.

The CS19-BBU-002-48 series provides an integrated power, battery charger and alarm monitor system. The power system provides up to 216W of power to the BDA with an additional 54W to maintain peak battery level. The alarm system has local information and auxiliary connections for remote monitoring. Electronics and batteries are housed in a NEMA 4 enclosure.

The CS19-BBU-002-48RA provides full NFPA 72/1221 indicator support with remote annunciator for -48Vdc BDAs. The CS19-BBU-002-48-B provides 280W to power two BDAs with an additional 54W to provide 12 hour battery capacity charging.

Lead-acid batteries are ordered separately and will determine the length of battery backup time.

Product Highlights

- 24-hour Back-up Capable
- NFPA 1221 Compliant
- AC Input, -48Vdc Output
- Local and Remote Monitoring
- Power system UL 60950-1 Listed
- Cabinet UL 508A Listed
- NEMA-4 Protection
- NEMA-4X hydrogen gas venting
- Thermostatically controlled fan for >40C , >35C for -B version

Applications

- Indoor/Outdoor
- NFPA Battery Backup for BDAs

Ordering information

| Part Number | Descriptions |
|-------------------|---|
| CS19-BBU-002-48 | NEMA-4, NFPA 1221 Compliant -48VDC Battery Backup |
| CS19-BBU-002-48-B | NEMA-4, NFPA 1221 Compliant -48Vdc BBU for powering two BDAs |
| CS19-BBU-002-48RA | NEMA-4, NFPA 72/1221 Compliant -48VDC BBU with remote annunciator |

Batteries Sold Separately

| Battery Recommendation for Westell Class A BDAs | | Must Buy (qty) |
|---|---|----------------|
| CS19-PYL12V160FT | 160AH, 12VDC AGM type Battery for BBU-002-48 series | 4 |
| CS19-PYL12V100FT | 100AH, 12VDC AGM type Battery for BBU-002-48 series | 4 |
| CS19-PYL12V45FS | 45AH, 12VDC AGM type Battery for BBU-002-48 series | 4 |

| 12 Hour Battery Selectory Chart | |
|---------------------------------|--------|
| Up to 180 watts | 45 AH |
| 180 to 250 watts | 100 AH |
| 24 Hour Battery Selectory Chart | |
| Up to 90 watts | 45 AH |
| 90 to 200 watts | 100 AH |
| 200 to 250 watts | 160 AH |



Annunciator Panel

CS19-BBU-002-48RA Shown with Annunciator

Specifications

| | |
|----------------------------|---|
| Input Voltage | 85-300 Vac |
| Input Frequency | 45 - 66 Hz |
| Input Current | 3.2A/110Vac, 1.2A/220Vac 4.2A/110Vac, 1.5A/220Vac (-B version) |
| Output Voltage | -43.5 to -57.6Vdc |
| Output Power | 270W max , 334W (-B version) |
| DC Load Breaker | 1 @ 15 Amps 2 @ 15 Amps (-B version) |
| Environmental | 0C to +50°C |
| Dimensions (W x H x D) In. | 36" x 26" x 14.4" |
| Weather Resistance | NEMA-4 |
| UL | 60950-1, 508A |
| Mounting | Wall/H-Frame |
| Cable Entries | 3 @ 3/4", 1 @ 1/2" |



WESTELL

WESTELL.COM

Westell® | CS19-BBU-002-48 Series

12/24 Hour NFPA Compliant Battery Back-up Enclosure



Alarm Information

Westell's CS19-BBU-002-48RA offers the industry's most extensive alarm and system information in both remote and local visual indicators. The -48 model offers standard NFPA 1221 alarms via relay contacts.

The -48RA model also offers visual indication using (AC Fail, Rectifier Fail & Low Battery) annunciator module that is placed externally, up to 2000 feet, internal visual indication for in-depth diagnostics, relay contacts for all visual alarms and an audio alarm. The audio alarm goes off when any alarm is present, and this audio can be muted until the alarm is cleared.

The -48 model offers standard NFPA 1221 battery backup alarms including AC Fail, Battery Charger Fail & Battery Low via local relay contacts.

Relay Contact and LED Visual Alarms (-48RA model only)

Westell's CS19-BBU-002-48RA offers the following set of alarms on relay contacts inside the BBU housing plus the internal alarm board LEDs, and the external annunciator panel LEDs that can be mounted as much as 2000 feet away:

- AC Power - Normal
- AC Fail/Battery Active
- Battery Capacity Low
- Battery Charger Fail
- RF Emitter Fail
- Donor Antenna Fail/Disconnect
- System Component Fail

An additional summary alarm relay contact is available to the Fire Panel. The internal alarm board also offers two additional diagnostic LEDs for local troubleshooting.

- Audio Alarm Muted (steady blinking)
- System Alarms (code blinking)
 - BDA Power Failure
 - BDA General Alarm
 - AC Fail/Battery Active
 - Power Rectifier Over Temperature
 - Fan Failure Alarm
 - BDA Cable Integrity Alarm
 - Remote Annunciator Cable Integrity Alarm

Mechanical Drawings - Inches [mm]

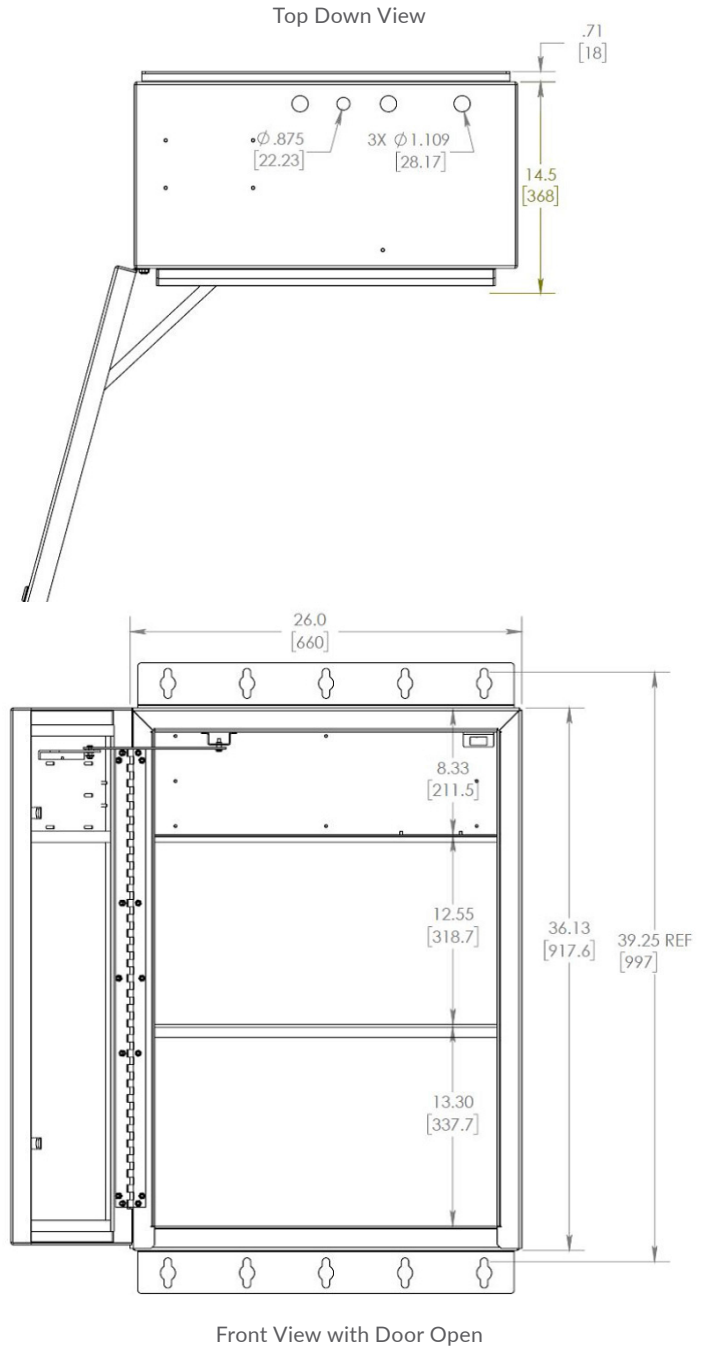

WESTELL

WESTELL.COM